



www.mazzer.com



KOLD



**Accessori Opzionali / Optionals / Options /
Optionals / Opcionales / Opções**

- Dosatura maggiorata (8-10,5 g) / Oversize dose (8-10,5 g - 0,28-0,36 oz) / Dose majorée (8-10,5 g) / Erhöhte Dosierung (8-10,5 g) / Dosis aumentada (8-10,5 g) / Dose maior (8-10,5 g)
- Pressino a molla con forchetta lunga / Spring coffee pressing device with long fork / Presse-café à ressort avec fourchette longue / Kleine Feder-presser mit langer Stützgabe / Prensador con resorte y horquilla larga / Prensador con mola e forquilha comprida
- Easy Tamper per dosatore / Easy Tamper for doser / Easy Tamper pour doseur / Easy Tamper für Dosierer / Easy Tamper para dosificador / Easy Tamper para doseador

COLOURS



**MACINADOSATORE KOLD
CON MACINE CONICHE**

REGOLAZIONE DI MACINATURA MICROMETRICA
VENTILAZIONE ELETTRONICA

Funzionamento automatico con avviamento ogni
12 dosi ed arresto al riempimento del dosatore.
Trasmissione a cinghia

CARATTERISTICHE TECNICHE:

Potenza	900 Watt
Macine coniche	
monofase rif. 186C	Ø 71 mm monofase
trifase rif. 187C	Ø 83 mm trifase
Giri macine	420 (50 Hz) g/min 500 (60 Hz) g/min
Capacità contenitore caffè in grani	1,5 Kg
Capacità contenitore caffè macinato	360 g
Regolazione della dose	5,5-8 g
Peso netto	30 Kg



**MOULIN DOSEUR KOLD
AVEC MEULES CONIQUES**

RÉGULATION DE MOUTURE MICROMÉTRIQUE
VENTILATION ÉLECTRONIQUE

Fonctionnement automatique avec démarrage toutes les
12 doses et arrêt à remplissage du doseur de café moulu.
Transmission par courroie

CARACTÉRISTIQUES TECHNIQUES:

Puissance	900 Watt
Meules coniques	
monophasé réf. 186C	Ø 71 mm monophasé
triphase réf. 187C	Ø 83 mm triphasé
Tours meules	420 (50 Hz) tr/min 500 (60 Hz) tr/min
Contenance de la trémie	1,5 Kg
Contenance du doseur	360 g
Réglage de la dose	5,5-8 g
Poids net	30 Kg



**MOLINO DOSIFICADOR KOLD
CON FRESAS CONICAS**

REGULACIÓN MICROMÉTRICA
VENTILACIÓN ELECTRÓNICA

Automático con puesta en marcha cada 12 dosificaciones y
parada cuando se llena el dosificador.
Transmisión por correa

DATOS TÉCNICOS:

Potencia	900 Watt
Fresas conicas	
monofásico ref. 186C	Ø 71 mm monofásico
trifásico ref. 187C	Ø 83 mm trifásico
Revoluciones fresas	420 (50 Hz) r.p.m. 500 (60 Hz) r.p.m.
Capacidad de la tolva	1,5 Kg
Capacidad de la dosis	360 g
Regulación de la dosis	5,5-8 g
Peso neto	30 Kg

CERTIFICATIONS



**GRINDER-DOSER KOLD
WITH CONICAL GRINDING BLADES**

MICROMETRICAL GRINDING ADJUSTMENT
VENTILATION WITH ELECTRONIC CONTROL

Automatic grinding cycle with start every 12 doses
and stop when the ground coffee doser is full.
Belt-driven transmission

TECHNICAL FEATURES:

Power	900 Watt
Conical grinding blades	
single phase ref. 186C	Ø 71 mm (2¾ inches) single phase
three phase ref. 187C	Ø 83 mm (3¼ inches) three phase
Grinding blade speed	420 (50 Hz) r.p.m. 500 (60 Hz) r.p.m.
Coffee-bean container capacity	1,5 Kg (3,3 lbs)
Ground coffee container capacity	360 g (0,8 lbs)
Dose adjustment	5,5-8 g (0,19 - 0,28 oz)
Net weight	30 Kg (66 lbs)



**DOSIERMÜHLE KOLD
MIT KONISCHE MAHLSCHLEIBEN**

MIKROMETRISCHE MAHLREGELUNG
ELEKTRONISCH-KONTROLLIERTE LUFTUNG

Automatische Mahlung mit Start bei jeder 12 Dosis
und Stop beim Anfüllen des Dosierers.
Riemenantrieb

TECHNISCHE DATEN:

Leistung	900 Watt
Konische Mahlschleiben	
einphasig Kennziffer 186C	Ø 71 mm einphasig
dreiphasig Kennziffer 187C	Ø 83 mm dreiphasig
Mahlschleibenumdrehungen	420 (50 Hz) r.p.m. 500 (60 Hz) r.p.m.
Kapazität des Bohnenbehälters	1,5 Kg
Kapazität des Dosierers	360 g
Einstellung der Kaffeepulverdosis	5,5-8 g
Nettogewicht	30 Kg



**MOINHO DOSEADOR KOLD
COM MÓIS CONICAS**

REGULAÇÃO MICROMÉTRICA
VENTILAÇÃO ELECTRONIC

Automático com partida a cada 12 doses e paragem
após o enchimento do doseador.
Transmissão por correia

DADOS TÉCNICOS:

Potencia	900 Watt
Móis conicas	
monofásico ref. 186C	Ø 71 mm monofásico
trifásico ref. 187C	Ø 83 mm trifásico
Rotações dos móis	420 (50 Hz) r.p.m. 500 (60 Hz) r.p.m.
Capacidade tremonha	1,5 Kg
Capacidade de café moído	360 g
Regulação de dose	5,5-8 g
Peso líquido	30 Kg

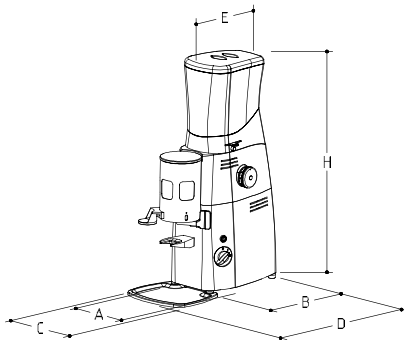

	mm	inches
A	215	8 ½
B	310	12 ¼
C	240	9 ½
D	480	19
E	240	9 ½
H	700	27 ¾

• Il costruttore si riserva la facoltà di apportare quelle modifiche tecniche che si rendessero necessarie senza preavviso. • The manufacturer reserves the right to change specifications without notice. • Le constructeur se réserve le droit d'effectuer des modifications sans aucun préavis. • Der Hersteller vorbehaltet sich den technischen Daten warnunglos zu ändern. • El constructor se reserva el derecho de efectuar sin previo aviso las modificaciones que considere oportunas en interés de mejoras técnicas en sus fabricados. • O constructor reserva-se o direito de modificar sem aviso previo as máquinas tratadas neste manual.